

ECONOMAX

AIR CYLINDERS

DESIGNED FOR TRUCKS AND TRAILERS



CORROSION RESISTANT

ICE RESISTANT SEALS

DURABLE

**BUILT
TO LAST**



www.economax.ca

ECONOMAX

AIR CYLINDERS

FEATURES:

- LONG LIFE
- PRE LUBRICATED
- 100% TESTED
- REPAIRABLE
- 250 PSI AIR
- LARGE BEARING
- CORROSION RESISTANT
- MADE IN CANADA
- NITRATE ROD
- STAINLESS TIE ROD & NUTS

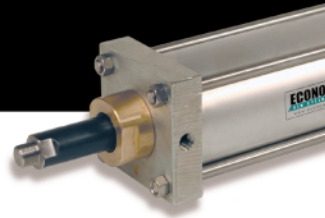

Air Cylinder Construction Features:

- Rod Wiper:** Urethane HW style wiper and secondary seal. Keeps dirt out. -65 to +220F
- Seal:** O-Ring gland seal. -65 to +220F
- End Seal:** Buna N gasket -65 to +220F
- Piston Rod:** Black nitrated ground piston rod provides superior corrosion resistance, better lubrication retention and dent resistance. Surface will not flake and cut rod seal like chrome plated shafting.
- Bearing:** 660 solid bearing bronze. Note extra long bearing surface for maximum support and resistance to side load. Threads are coated with anti-seize for easy removal.
- Tube:** Aluminum alloy tube with a hard-coated "Alumite" smooth bore that has excellent resistance to sliding type wear and abrasion. All cylinders are pre-lubricated for millions of trouble-free cycles.
- End Caps:** Steel with yellow zinc dichromate finish for superior strength and corrosion resistance.
- Tie Rods:** Stainless steel with stainless nuts for corrosion resistance.
- Piston:** Aluminum 6061T6 machined on piece, anaerobically and mechanically locked to the piston.
- Piston Seal:** Buna N T-Seal, combination of hard split back up rings on each side of sealing element provides a non-spiraling, ice resistant durable seal. -65 to +220
- Wear Strip:** Reinforced nylon with bronze properties. Prevents tube scoring and helps with breakaway in freezing conditions.
- Rod Seal:** HRU 80 durometer Buna N style U cup Navy spec. AN6266 -40 to +250F

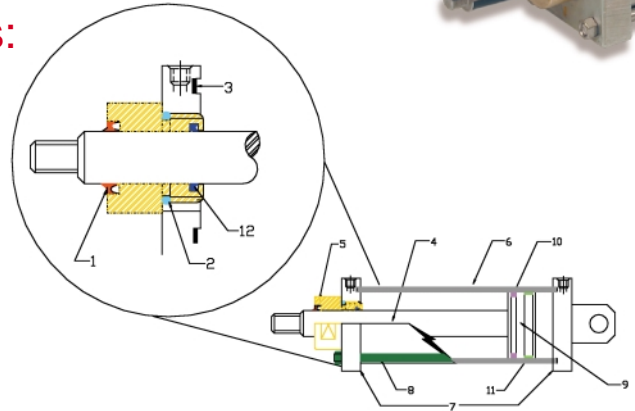

Dimensions:

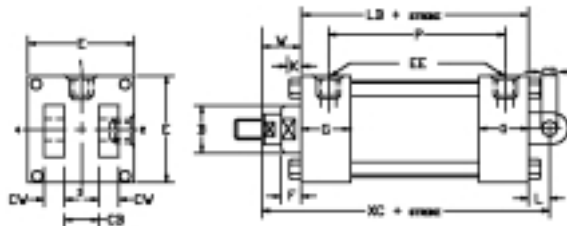

BORE	B	CB	CD	CW	E	EE NPT	F	L	G	K	W*	ADD STROKE		
												LB*	P*	XC*
2 1/2	2	3/4	1/2	1/2	3	1/4	1	3/4	1	5/16	1 3/4	3 1/4	2 1/4	5 3/4
3 1/4	2	1 1/4	3/4	5/8	3 3/4	1/4	1	1 1/4	1	3/8	1 3/4	3 1/4	2 1/4	6 1/4
4	2	1 1/4	3/4	5/8	4 1/2	3/8	1	1 1/4	1	3/8	1 3/4	3 1/4	2 1/4	6 1/4
5	2	1 1/4	3/4	5/8	5 1/2	3/8	1	1 1/4	1	1/2	1 3/4	3 1/2	2 1/2	6 1/2

* Minimum dimension. Typical are usually longer as shown on the "Stock Size List".

Stock Sizes:

BORE	STROKE	KK	XC	A	B	C	D	MM
3 1/4	6	3/4-16	13 1/2	1 1/8	2	2	13/16	1
3 1/4	8	5/8-18	15 3/4	1/2	2	2 1/4	13/16	1
4	14	3/4-16	21	1 1/8	2	1 1/2	13/16	1
4	16	3/4-16	24 7/8	1 1/8	2	3 3/8	13/16	1
5	14	3/4-16	21 7/8	1 1/8	2	2 1/8	13/16	1
5	16	3/4-16	23 7/8	1 1/8	2	2 1/8	13/16	1
5	16	1-14	25 5/8	2 1/4	2	3 7/8	13/16	1
5	18	3/4-16	25 3/4	1 1/8	2	2	13/16	1

*These are the common pin to shoulder dimensions. Any other length is available.

Rod End

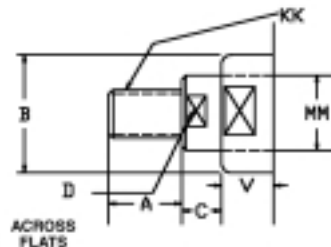

DESIGNED FOR TRUCKS AND TRAILERS

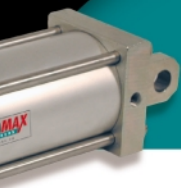

Accessories:

Rod Clevis

	A	CB	CD	CE	CH	CW	ER	F	KK	L
BDC-05	3/4	.765	1/2	1 1/2	1	1/2	1/2	1	7/16-20	3/4
BDC-061-1/2P/ZD	1/2	.55	1/2	1 3/4	N/A	.35	1/2	N/A	5/8-18	1 1/4
BDC-07M/ZD	1 1/8	1.265	3/4	2 1/8	1 3/8	5/8	3/4	1 1/4	3/4-16	1
BDC-10M	1 5/8	1.515	1	2 5/16	1 1/2	3/4	1	1 5/8	1-14	1 5/16

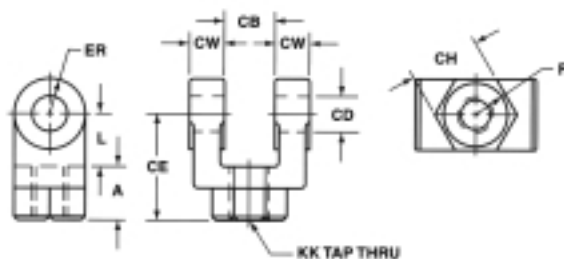

Rod Eye

	A	CA	CB	CD	ER	KK
BDE-05	3/4	1 1/2	3/4	1/2	5/8	7/16-20
BDE-07/ZD	1 1/8	2 1/16	1 1/4	3/4	7/8	3/4-16
BDE-10	1 5/8	2 13/16	1 1/2	1	1 3/16	1-14

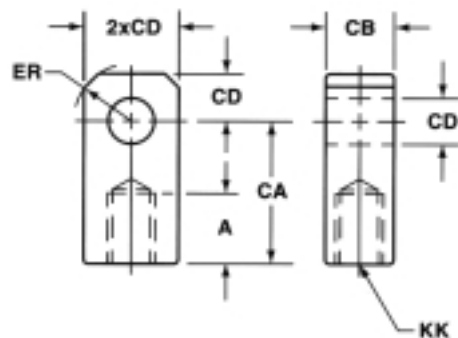

Pins

	CD	A	B	C	D
BPD-05H	1/2	2.281	1.938	.172	.106
P-05-KO/ZD*	1/2	1.665	1.350	.16	.16
BDP-07H/ZD	3/4	3.094	2.719	.188	.14
BDP-10H	1	3.594	3.219	.188	.14

Pins with /ZD are Yellow Zinc Dichomate plated. Others are Black Oxide plated. Plated cotter pins included with all pins.

*P-05 pin has a head on one end.

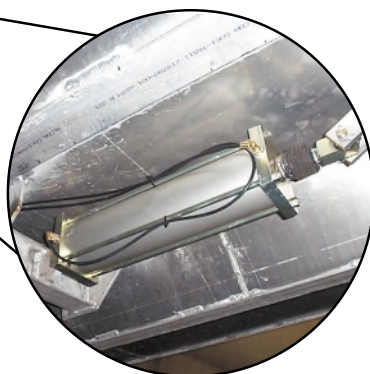
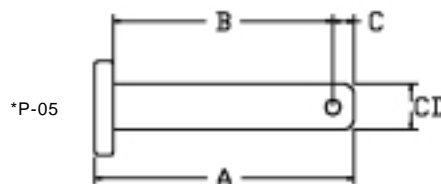
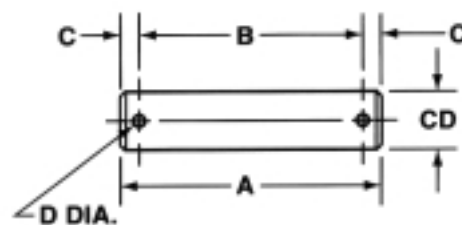

**AIR GATE AND
TARP PULL SYSTEMS**

ECONOMAX
AIR CYLINDERS

HOW TO ORDER ECONOMAX CYLINDERS

Specify pin to shoulder dimension in description

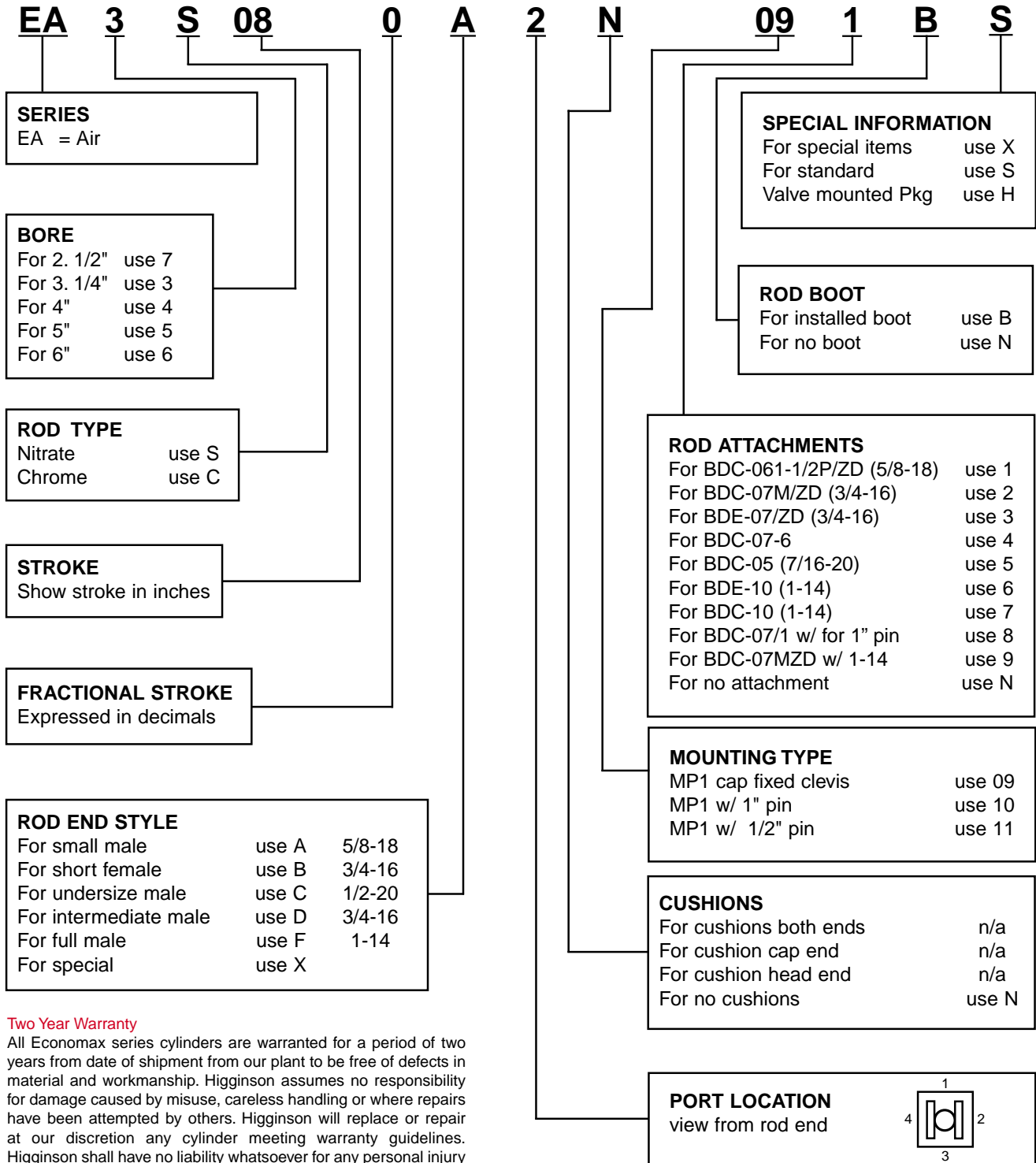

Two Year Warranty

All Economax series cylinders are warranted for a period of two years from date of shipment from our plant to be free of defects in material and workmanship. Higginson assumes no responsibility for damage caused by misuse, careless handling or where repairs have been attempted by others. Higginson will replace or repair at our discretion any cylinder meeting warranty guidelines. Higginson shall have no liability whatsoever for any personal injury or property damage however arising.